

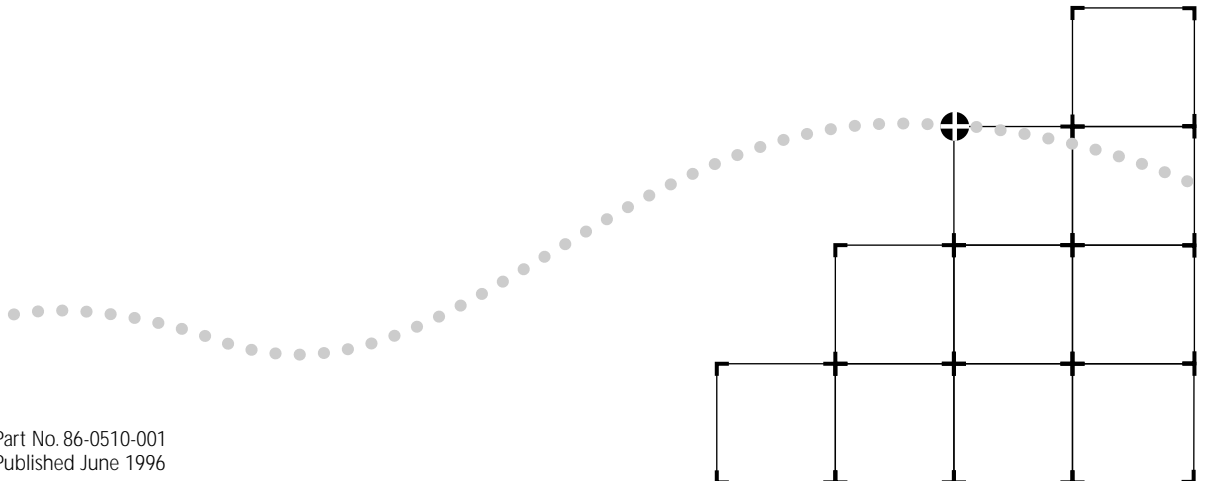

ACCESSBUILDER™ 4000 UPGRADE PROCEDURE



Part No. 86-0510-001
Published June 1996

ACCESSBUILDER 4000 UPGRADE PROCEDURE

For Version 6.1 Software

Hardware Compatibility

The following guidelines describe when this upgrade applies to your specific hardware:



AccessBuilder 4000

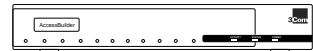

AccessBuilder

AccessBuilder 4000	AccessBuilder
AccessBuilder 4000 async systems can be upgraded to ISDN Version 6.1 with the addition of ISDN module(s) AccessBuilder 4000 ISDN systems can be upgraded as is. Additional memory not required.	AccessBuilder async systems can be upgraded to the ISDN package with the addition of ISDN module(s) Requires extra memory (flash/DRAM) before loading Version 6.1

Purpose

This document provides instructions on upgrading the AccessBuilder 4000 internal memory as required by Version 6.01 of the AccessBuilder software.

The AccessBuilder 4000 upgrade kit consists of:

- one 256K X 8 Flash chip,
- two 256K X 8 DRAM chips,
- these instructions

Overview

The upgrade procedure takes about 10 to 15 minutes to complete. Only a small flat-blade screwdriver is necessary.

This kit increases both the AccessBuilder 4000's internal Flash program memory, and the shared DRAM each to 1Mb, which is required for Version 6.1 operation.

Procedure

General Considerations

These procedures require the AccessBuilder 4000 unit be taken off-line and powered down for a short period of time. Be sure to schedule the upgrade so as to have minimal impact on your users.

If you are upgrading a previously configured AccessBuilder 4000, your existing configuration information will not be affected by this procedure.

Removing the Main Processor Board

- 1 If currently on, power down the AccessBuilder 4000, and disconnect all cables connecting to the AccessBuilder 4000 main processor board (remove the power cable as well).



The Flash chip and the DRAM chips are sensitive to static electricity. Observe static handling precautions: discharge any static on your body by touching a metal surface of the AccessBuilder 4000 before touching any component.

- Using a flat blade screwdriver, unscrew the two main processor board screws and remove the main processor board by pulling the board out.

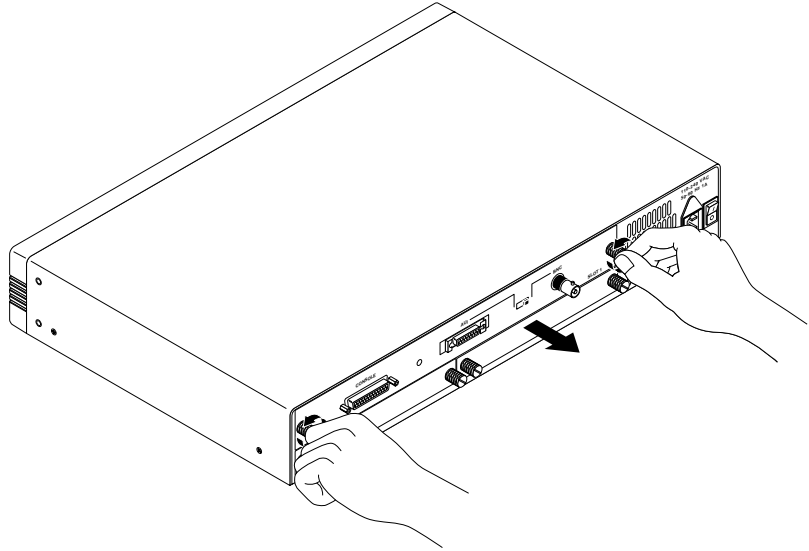

Figure 1 Removing the Main Processor Board.



It may be necessary to first remove the I/O boards due to the presence of small EMI rounding clips on the I/O boards that may obstruct the bottom edge of the main processor board.

- Place the main processor board on a flat surface with the rear panel toward you.

Flash Upgrade

- Locate the empty socket for the Flash chip (just below the Intel i960 processor. The socket is labelled U44 (refer to the following illustration).

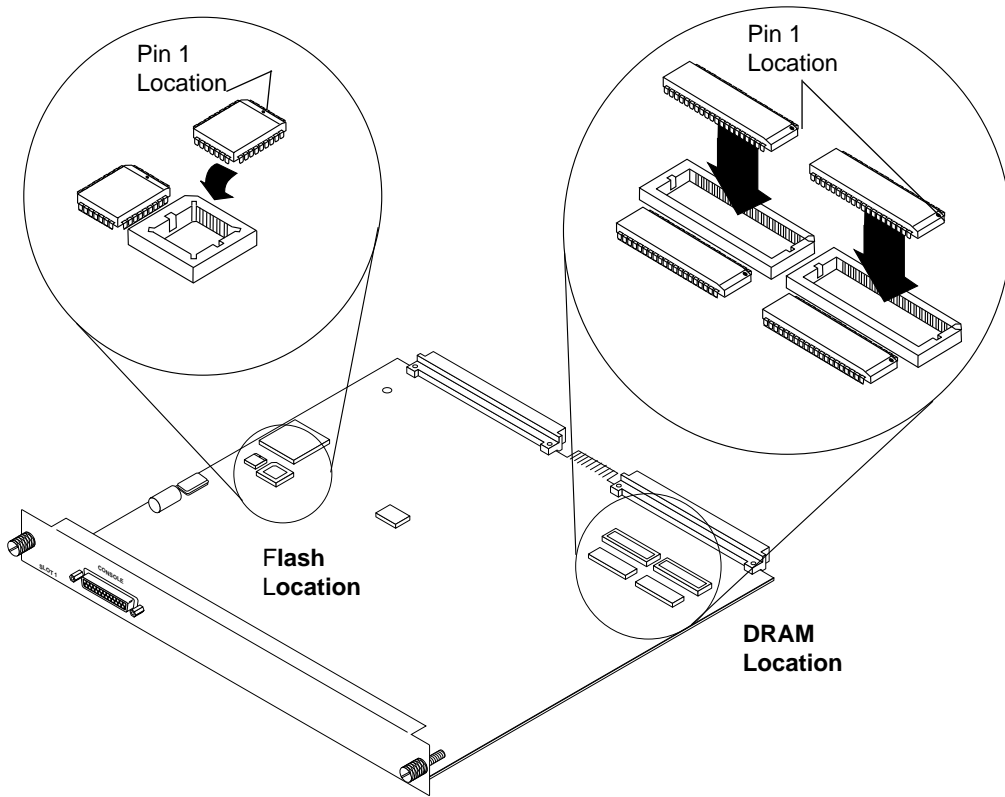

Figure 2 Flash and DRAM Socket Locations

- 2** Find pin 1 on the empty Flash socket. It is the middle pin on the socket edge nearest the i960. Refer to Figure 2 for details.
- 3** Remove the Flash chip from the upgrade kit. Open the anti-static box containing chip and remove the chip. The word "Flash" appears on the chip: directly above is a beveled edge containing a dot in the center (refer to Figure 2).
- 4** Insert the new Flash chip by aligning its pin one with the mating pin one on the socket and gently press the chip into the socket until it is fully seated.

DRAM Upgrade

- 1 Locate the two empty sockets near the right-hand connector on the rear of the main processor board (see Figure 1).
- 2 Locate the arrow in the upper right-hand corner of the empty sockets. This is pin 1. Refer to Figure 2 for details.
- 3 Remove the two 40-pin DRAM chips from the upgrade kit and remove them from their anti-static bag. Locate pin 1 on a DRAM chip (slanted edge - see Figure 2 for details).
- 4 Orient the DRAM chip to the socket so that pin 1's will mate when the chip is placed in the socket. Place the chip on the socket so it is resting on the top of the socket, parallel to the printed circuit board with the leads of the socket and chip aligned. (If one side of the DRAM chip drops into the socket, it is not possible to press the other side down: insertion can only occur when the chip is parallel the bottom of the socket). Gently press both ends of the chip into the socket until it is fully seated. Repeat the process for the remaining chip.

Proceed to the following step.

Reinstalling The Main Processor Board

Reinsert the main processor board into its slot. Be sure the board edges are engaged in the card guide on each side.

- 1 Slide the card into the chassis until the card engages the backplane connectors.
- 2 Secure the main processor board in the slot by tightening the captive screws.



A solid connection of the main processor board to the chassis is required for proper operation, but the screws should not be used to force the card into place.

- 3 Reattach the cables to the main processor board removed in Step 1, and reconnect the power cable.
- 4 Power on the AccessBuilder 4000.

- 5 The AccessBuilder 4000 system will go directly to the Nindy prompt ("C>") on the attached console. Issue the following commands to the AccessBuilder 4000:

-> **ts**

-> **2**

This will show the AccessBuilder system configuration., which should show:

-Shared DRAM : 0 X 800 KB

Flash RAM : 0 X 400 KB



If the Flash chip or a DRAM chip is not properly installed, the system will not enter the Nindy mode. If the Nindy prompt does not appear, power down the AccessBuilder 4000 and remove the motherboard. Carefully inspect the chips you installed or correction orientation, and proper seating in the socket. If necessary, use a small flat-blade screwdriver to remove the mis-oriented chip and re-install. Repeat the above procedure from step 1.

- 6 Proceed to the section, Upgrade Procedures, in the AccessBuilder 4000 Version 6.1 Release Notes.